

DIMENSION TABLES

**LINEAR BALL BEARINGS
SERIES LM..**

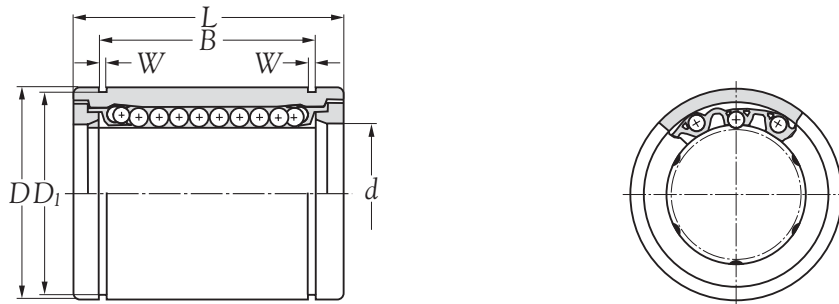

Boundary dimensions <i>d</i> mm	Bearing number				Number of ball tracks	Principal dimensions					
	standard steel retainer	standard resin retainer	standard steel retainer	standard resin retainer		<i>d</i>		<i>D</i>		<i>L</i>	
						mm	0.001mm	mm	0.001mm	mm	mm
5	LM5A	LM5	LM5A UU	LM5 UU	4	5	(0/-8)	10	(0/-9)	15	(0/-0.2)
6	LM6A	LM6	LM6A UU	LM6 UU	4	6	(0/-9)	12	(0/-11)	19	(0/-0.2)
8	LM8SA	LM8S	LM8SA UU	LM8S UU	4	8	(0/-9)	15	(0/-11)	17	(0/-0.2)
8	LM8A	LM8	LM8A UU	LM8 UU	4	8	(0/-9)	15	(0/-11)	24	(0/-0.2)
10	LM10A	LM10	LM10A UU	LM10 UU	4	10	(0/-9)	19	(0/-13)	29	(0/-0.2)
12	LM12A	LM12	LM12A UU	LM12 UU	4	12	(0/-9)	21	(0/-13)	30	(0/-0.2)
13	LM13A	LM13	LM13A UU	LM13 UU	4	13	(0/-9)	23	(0/-13)	32	(0/-0.2)
16	LM16A	LM16	LM16A UU	LM16 UU	5	16	(0/-9)	28	(0/-13)	37	(0/-0.2)
20	LM20A	LM20	LM20A UU	LM20 UU	5	20	(0/-10)	32	(0/-16)	42	(0/-0.2)
25	LM25A	LM25	LM25A UU	LM25 UU	6	25	(0/-10)	40	(0/-16)	59	(0/-0.3)
30	LM30A	LM30	LM30A UU	LM30 UU	6	30	(0/-10)	45	(0/-16)	64	(0/-0.3)
35	LM35A	LM35	LM35A UU	LM35 UU	6	35	(0/-12)	52	(0/-16)	70	(0/-0.3)
40	LM40A	LM40	LM40A UU	LM40 UU	6	40	(0/-12)	60	(0/-16)	80	(0/-0.3)
50	LM50A	LM50	LM50A UU	LM50 UU	6	50	(0/-12)	80	(0/-19)	100	(0/-0.3)
60	LM60A	LM60	LM60A UU	LM60 UU	6	60	(0/-15)	90	(0/-19)	110	(0/-0.3)

LINEAR BALL BEARINGS

SERIES LM..

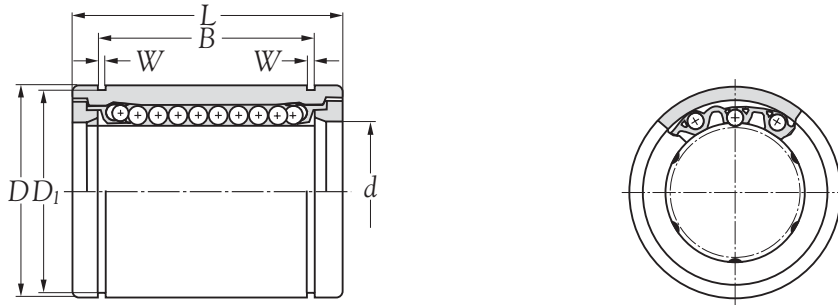

B tolerance	Principal dimensions		Roundness 0.001mm	Steel retainer maximum radial clearance 0.001mm	Load ratings		Mass kg (approx.)
	W mm	D ₁			dynamic C N	static C ₀	
10.2 (0/-0.2)	1.10	9.6	8	-3	17	21	0.0040
13.5 (0/-0.2)	1.10	11.5	12	-5	21	27	0.0080
11.5 (0/-0.2)	1.10	14.3	12	-5	18	23	0.0110
17.5 (0/-0.2)	1.10	14.3	12	-5	27	41	0.0160
22.0 (0/-0.2)	1.30	18.0	12	-5	38	56	0.0300
23.0 (0/-0.2)	1.30	20.0	12	-5	42	61	0.0315
23.0 (0/-0.2)	1.30	22.0	12	-7	52	79	0.0430
26.5 (0/-0.2)	1.60	27.0	12	-7	79	120	0.0690
30.5 (0/-0.2)	1.60	30.5	15	-9	88	140	0.0870
41.0 (0/-0.3)	1.85	38.0	15	-9	100	160	0.2200
44.5 (0/-0.3)	1.85	43.0	15	-9	160	280	0.2500
49.5 (0/-0.3)	2.10	49.0	20	-13	170	320	0.3900
60.5 (0/-0.3)	2.10	57.0	20	-13	220	410	0.5850
74.0 (0/-0.3)	2.60	76.5	20	-13	390	810	1.5800
85.0 (0/-0.3)	3.15	86.5	25	-16	480	1020	2.0000

LINEAR BALL BEARINGS
SERIES LM..AJ

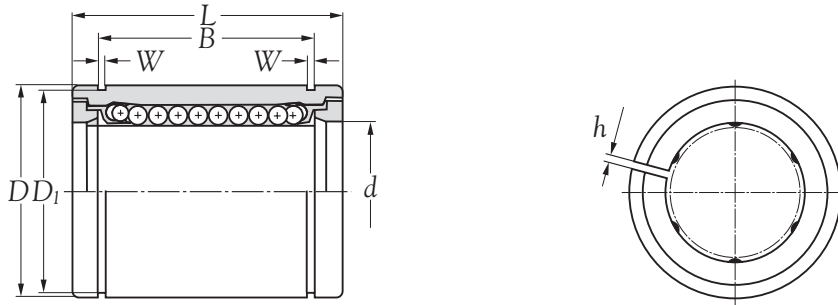

Boundary dimensions <i>d</i> mm	Bearing number				Number of ball tracks	Principal dimensions					
	standard steel retainer	standard resin retainer	standard steel retainer	standard resin retainer		<i>d</i>		<i>D</i>		<i>L</i>	
						mm	0.001mm	mm	0.001mm	mm	mm
5	LM5A-AJ	LM5-AJ	LM5A UU-AJ	LM5 UU-AJ	4	5	(0/-8)	10	(0/-9)	15	(0/-0.2)
6	LM6A-AJ	LM6-AJ	LM6A UU-AJ	LM6 UU-AJ	4	6	(0/-9)	12	(0/-11)	19	(0/-0.2)
8	LM8SA-AJ	LM8S-AJ	LM8SA UU-AJ	LM8S UU-AJ	4	8	(0/-9)	15	(0/-11)	17	(0/-0.2)
8	LM8A-AJ	LM8-AJ	LM8A UU-AJ	LM8 UU-AJ	4	8	(0/-9)	15	(0/-11)	24	(0/-0.2)
10	LM10A-AJ	LM10-AJ	LM10A UU-AJ	LM10 UU-AJ	4	10	(0/-9)	19	(0/-13)	29	(0/-0.2)
12	LM12A-AJ	LM12-AJ	LM12A UU-AJ	LM12 UU-AJ	4	12	(0/-9)	21	(0/-13)	30	(0/-0.2)
13	LM13A-AJ	LM13-AJ	LM13A UU-AJ	LM13 UU-AJ	4	13	(0/-9)	23	(0/-13)	32	(0/-0.2)
16	LM16A-AJ	LM16-AJ	LM16A UU-AJ	LM16 UU-AJ	5	16	(0/-9)	28	(0/-13)	37	(0/-0.2)
20	LM20A-AJ	LM20-AJ	LM20A UU-AJ	LM20 UU-AJ	5	20	(0/-10)	32	(0/-16)	42	(0/-0.2)
25	LM25A-AJ	LM25-AJ	LM25A UU-AJ	LM25 UU-AJ	6	25	(0/-10)	40	(0/-16)	59	(0/-0.3)
30	LM30A-AJ	LM30-AJ	LM30A UU-AJ	LM30 UU-AJ	6	30	(0/-10)	45	(0/-16)	64	(0/-0.3)
35	LM35A-AJ	LM35-AJ	LM35A UU-AJ	LM35 UU-AJ	6	35	(0/-12)	52	(0/-16)	70	(0/-0.3)
40	LM40A-AJ	LM40-AJ	LM40A UU-AJ	LM40 UU-AJ	6	40	(0/-12)	60	(0/-16)	80	(0/-0.3)
50	LM50A-AJ	LM50-AJ	LM50A UU-AJ	LM50 UU-AJ	6	50	(0/-12)	80	(0/-19)	100	(0/-0.3)
60	LM60A-AJ	LM60-AJ	LM60A UU-AJ	LM60 UU-AJ	6	60	(0/-15)	90	(0/-19)	110	(0/-0.3)

LINEAR BALL BEARINGS
SERIES LM..AJ

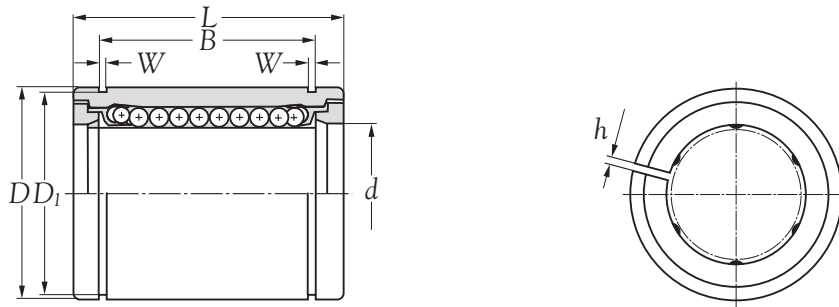

B tolerance	Principal dimensions			Roundness 0.001mm	Steel retainer maximum radial clearance 0.001mm	Load ratings		Mass kg (approx.)
	W mm	D ₁	h			dynamic C N	static C ₀	
10.2 (0/-0.2)	1.10	9.6	-	8	-3	17	21	0.004
13.5 (0/-0.2)	1.10	11.5	1.0	12	-5	21	27	0.008
11.5 (0/-0.2)	1.10	14.3	1.0	12	-5	18	23	0.011
17.5 (0/-0.2)	1.10	14.3	1.0	12	-5	27	41	0.016
22.0 (0/-0.2)	1.30	18.0	1.0	12	-5	38	56	0.030
23.0 (0/-0.2)	1.30	20.0	1.5	12	-5	42	61	0.032
23.0 (0/-0.2)	1.30	22.0	1.5	12	-7	52	79	0.043
26.5 (0/-0.2)	1.60	27.0	1.5	12	-7	79	120	0.069
30.5 (0/-0.2)	1.60	30.5	1.5	15	-9	88	140	0.087
41.0 (0/-0.3)	1.85	38.0	2.0	15	-9	100	160	0.220
44.5 (0/-0.3)	1.85	43.0	2.5	15	-9	160	280	0.250
49.5 (0/-0.3)	2.10	49.0	2.5	20	-13	170	320	0.390
60.5 (0/-0.3)	2.10	57.0	3.0	20	-13	220	410	0.585
74.0 (0/-0.3)	2.60	76.5	3.0	20	-13	390	810	1.580
85.0 (0/-0.3)	3.15	86.5	3.0	25	-16	480	1020	2.000

LINEAR BALL BEARINGS
SERIES LM..OP

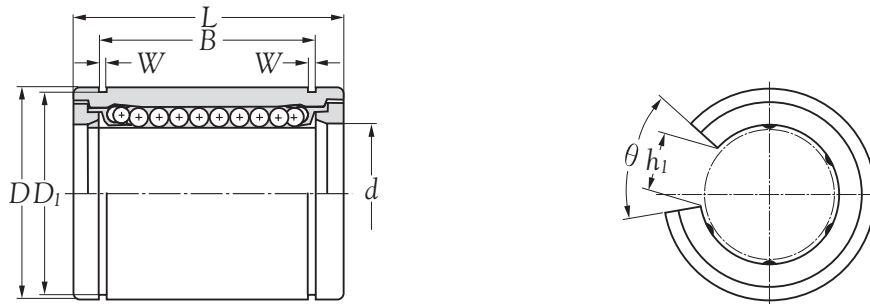

Boundary dimensions <i>d</i> mm	Bearing number				Number of ball tracks	Principal dimensions					
	standard steel retainer	standard resin retainer	standard steel retainer	standard resin retainer		<i>d</i>		<i>D</i>		<i>L</i>	
						tolerance mm	0.001mm	tolerance mm	0.001mm	tolerance mm	mm
5	LM5A-OP	LM5-OP	LM5A UU-OP	LM5 UU-OP	4	5	(0/-8)	10	(0/-9)	15	(0/-0.2)
6	LM6A-OP	LM6-OP	LM6A UU-OP	LM6 UU-OP	4	6	(0/-9)	12	(0/-11)	19	(0/-0.2)
8	LM8SA-OP	LM8S-OP	LM8SA UU-OP	LM8S UU-OP	4	8	(0/-9)	15	(0/-11)	17	(0/-0.2)
8	LM8A-OP	LM8-OP	LM8A UU-OP	LM8 UU-OP	4	8	(0/-9)	15	(0/-11)	24	(0/-0.2)
10	LM10A-OP	LM10-OP	LM10A UU-OP	LM10 UU-OP	4	10	(0/-9)	19	(0/-13)	29	(0/-0.2)
12	LM12A-OP	LM12-OP	LM12A UU-OP	LM12 UU-OP	4	12	(0/-9)	21	(0/-13)	30	(0/-0.2)
13	LM13A-OP	LM13-OP	LM13A UU-OP	LM13 UU-OP	4	13	(0/-9)	23	(0/-13)	32	(0/-0.2)
16	LM16A-OP	LM16-OP	LM16A UU-OP	LM16 UU-OP	5	16	(0/-9)	28	(0/-13)	37	(0/-0.2)
20	LM20A-OP	LM20-OP	LM20A UU-OP	LM20 UU-OP	5	20	(0/-10)	32	(0/-16)	42	(0/-0.2)
25	LM25A-OP	LM25-OP	LM25A UU-OP	LM25 UU-OP	6	25	(0/-10)	40	(0/-16)	59	(0/-0.3)
30	LM30A-OP	LM30-OP	LM30A UU-OP	LM30 UU-OP	6	30	(0/-10)	45	(0/-16)	64	(0/-0.3)
35	LM35A-OP	LM35-OP	LM35A UU-OP	LM35 UU-OP	6	35	(0/-12)	52	(0/-16)	70	(0/-0.3)
40	LM40A-OP	LM40-OP	LM40A UU-OP	LM40 UU-OP	6	40	(0/-12)	60	(0/-16)	80	(0/-0.3)
50	LM50A-OP	LM50-OP	LM50A UU-OP	LM50 UU-OP	6	50	(0/-12)	80	(0/-9)	100	(0/-0.3)
60	LM60A-OP	LM60-OP	LM60A UU-OP	LM60 UU-OP	6	60	(0/-15)	90	(0/-9)	110	(0/-0.3)

LINEAR BALL BEARINGS
SERIES LM..OP

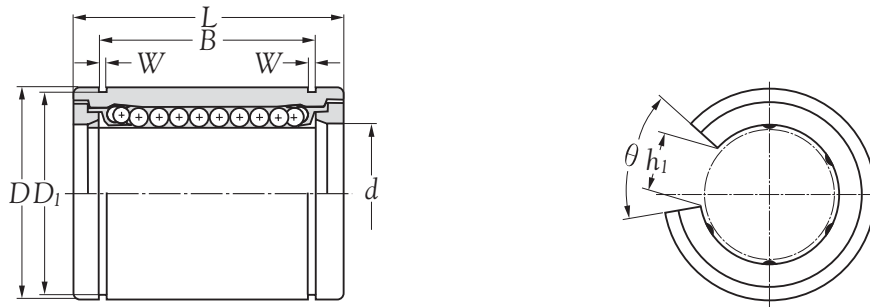

B	Principal dimensions					Roundness	Steel retainer maximum radial clearance	Load ratings		Mass kg (approx.)
	tolerance	W	D ₁	h ₁	θ			dynamic C	static C ₀	
		mm					0.001mm	0.001mm		
10.2	(0/-0.2)	1.10	9.6	-	-	8	-3	17	21	0.004
13.5	(0/-0.2)	1.10	11.5	-	-	12	-5	21	27	0.008
11.5	(0/-0.2)	1.10	14.3	-	-	12	-5	18	23	0.011
17.5	(0/-0.2)	1.10	14.3	-	-	12	-5	27	41	0.016
22.0	(0/-0.2)	1.30	18.0	-	-	12	-5	38	56	0.030
23.0	(0/-0.2)	1.30	20.0	8	80°	12	-5	42	61	0.032
23.0	(0/-0.2)	1.30	22.0	9	80°	12	-7	52	79	0.043
26.5	(0/-0.2)	1.60	27.0	11	60°	12	-7	79	120	0.069
30.5	(0/-0.2)	1.60	30.5	11	60°	15	-9	88	140	0.087
41.0	(0/-0.3)	1.85	38.0	12	50°	15	-9	100	160	0.220
44.5	(0/-0.3)	1.85	43.0	15	50°	15	-9	160	280	0.250
49.5	(0/-0.3)	2.10	49.0	17	50°	20	-13	170	320	0.390
60.5	(0/-0.3)	2.10	57.0	20	50°	20	-13	220	410	0.585
74.0	(0/-0.3)	2.60	76.5	25	50°	20	-13	390	810	1.580
85.0	(0/-0.3)	3.15	86.5	30	50°	25	-16	480	1020	2.000

LINEAR BALL BEARINGS
SERIES LMF..F

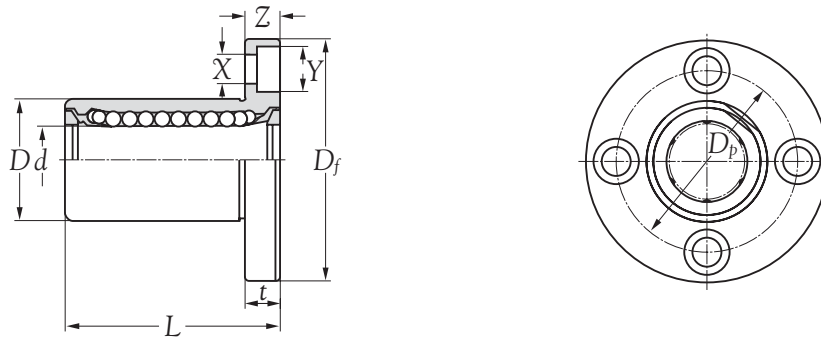

Boundary dimensions <i>d</i> mm	Bearing number		Number of ball tracks	Principal dimensions					
	standard resin retainer	with seals resin retainer		<i>d</i>		<i>D</i>		<i>L</i>	
				tolerance mm	0.001mm	tolerance mm	0.001mm	tolerance mm	mm
8	LMF8	LMF8 UU	4	8	(+8/0)	16	(0/-13)	25	(±0.3)
12	LMF12	LMF12 UU	4	12	(+8/0)	22	(0/-16)	32	(±0.3)
16	LMF16	LMF16 UU	5	16	(+9/-1)	26	(0/-16)	36	(±0.3)
20	LMF20	LMF20 UU	5	20	(+9/-1)	32	(0/-19)	45	(±0.3)
25	LMF25	LMF25 UU	6	25	(+11/-1)	40	(0/-19)	58	(±0.3)
30	LMF30	LMF30 UU	6	30	(+11/-1)	47	(0/-19)	68	(±0.3)
40	LMF40	LMF40 UU	6	40	(+13/-2)	62	(0/-22)	80	(±0.3)
50	LMF50	LMF50 UU	6	50	(+13/-2)	75	(0/-22)	100	(±0.3)
60	LMF60	LMF60 UU	6	60	(+13/-2)	90	(0/-25)	125	(±0.3)

LINEAR BALL BEARINGS
SERIES LM..F

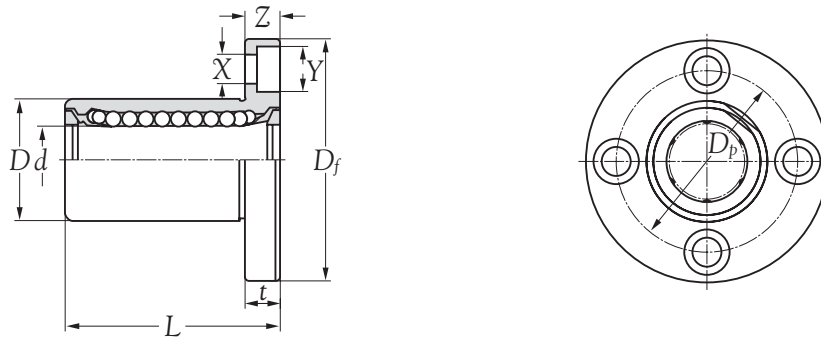

D_f	Principal dimensions flange			Roundness 0.001mm	Squareness 0.001mm	Load ratings		Mass kg (approx.)
	t	D_p	$X \times Y \times Z$			dynamic C	static C_o	
	mm					N		
32	5	24	3.5 × 6.0 × 3.1	12	12	265	402	0.041
42	6	32	4.5 × 7.5 × 4.1	12	12	510	784	0.080
46	6	36	4.5 × 7.5 × 4.1	12	12	578	892	0.103
54	8	43	5.5 × 9.0 × 5.1	15	15	862	1370	0.182
62	8	51	5.5 × 9.0 × 5.1	15	15	980	1570	0.335
76	10	62	6.6 × 11 × 6.1	15	15	1570	2740	0.560
98	13	80	9.0 × 14 × 8.1	17	17	2160	4020	1.175
112	13	94	9.0 × 14 × 8.1	17	17	3820	7940	1.745
134	18	112	11.0 × 17 × 11.1	20	20	4700	9800	3.220

LINEAR BALL BEARINGS
SERIES LMK..K

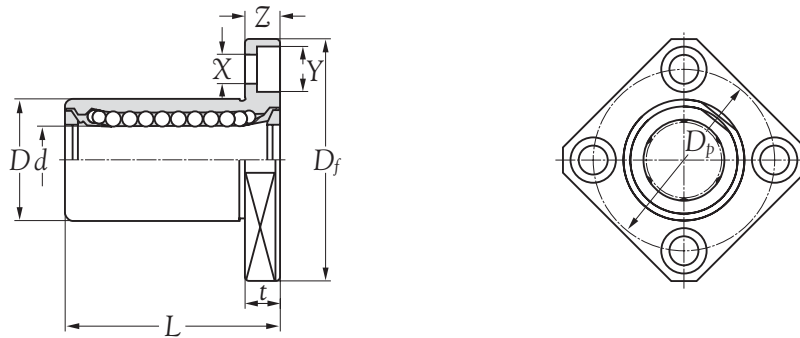

Boundary dimensions <i>d</i> mm	Bearing number		Number of ball tracks	Principal dimensions					
	standard resin retainer	with seals resin retainer		<i>d</i>		<i>D</i>		<i>L</i>	
				tolerance mm	0.001mm	tolerance mm	0.001mm	tolerance mm	mm
8	LMK8	LMK8 UU	4	8	(+8/0)	16	(0/-13)	25	(±0.3)
12	LMK12	LMK12 UU	4	12	(+8/0)	22	(0/-16)	32	(±0.3)
16	LMK16	LMK16 UU	5	16	(+9/-1)	26	(0/-16)	36	(±0.3)
20	LMK20	LMK20 UU	5	20	(+9/-1)	32	(0/-19)	45	(±0.3)
25	LMK25	LMK25 UU	6	25	(+11/-1)	40	(0/-19)	58	(±0.3)
30	LMK30	LMK30 UU	6	30	(+11/-1)	47	(0/-19)	68	(±0.3)
40	LMK40	LMK40 UU	6	40	(+13/-2)	62	(0/-22)	80	(±0.3)
50	LMK50	LMK50 UU	6	50	(+13/-2)	75	(0/-22)	100	(±0.3)
60	LMK60	LMK60 UU	6	60	(+13/-2)	90	(0/-25)	125	(±0.3)

LINEAR BALL BEARINGS
SERIES LM..K

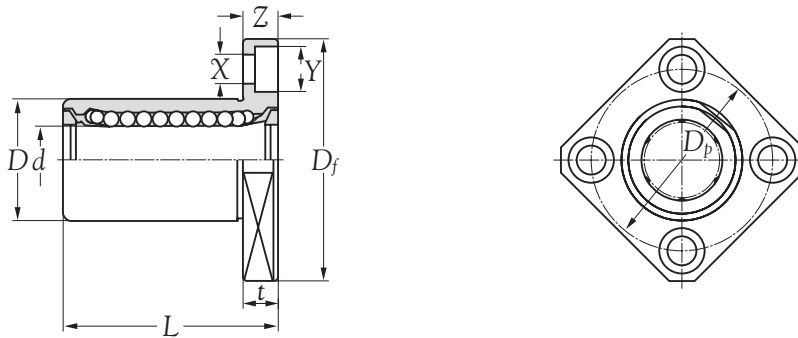

D_f	Principal dimensions flange			Roundness 0.001mm	Squareness 0.001mm	Load ratings		Mass kg (approx.)
	t	D_p	$X \times Y \times Z$			dynamic C	static C_o	
mm						N		
32	5	24	3.5 x 6.0 x 3.1	12	12	265	402	0.041
42	6	32	4.5 x 7.5 x 4.1	12	12	510	784	0.080
46	6	36	4.5 x 7.5 x 4.1	12	12	578	892	0.103
54	8	43	5.5 x 9.0 x 5.1	15	15	862	1370	0.182
62	8	51	5.5 x 9.0 x 5.1	15	15	980	1570	0.335
76	10	62	6.6 x 11 x 6.1	15	15	1570	2740	0.560
98	13	80	9.0 x 14 x 8.1	17	17	2160	4020	1.175
112	13	94	9.0 x 14 x 8.1	17	17	3820	7940	1.745
134	18	112	11.0 x 17 x 11.1	20	20	4700	9800	3.220

LINEAR BALL BEARINGS
SERIES LMB

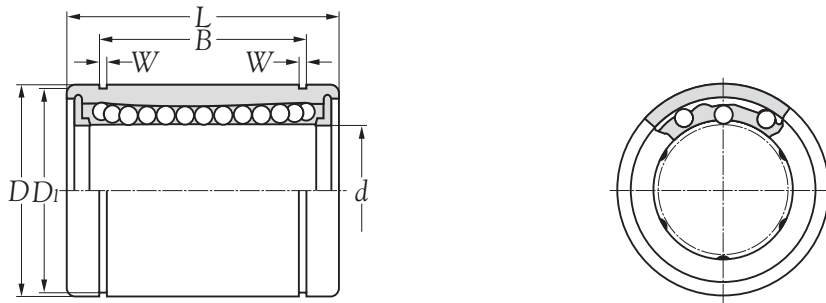

Boundary dimensions <i>d</i> mm/inch	Bearing number				Number of ball tracks	Principal dimensions					
	standard steel retainer	standard resin retainer	standard steel retainer	standard resin retainer		<i>d</i>		<i>D</i>		<i>L</i>	
					tolerance	tolerance	tolerance	tolerance	tolerance	tolerance	tolerance
					mm/inch	0.001mm/inch	mm/inch	0.001mm/inch	mm/inch	0.001mm/inch	mm/inch
6.350 1/4	-	LMB4	-	LMB4 UU	4	6.350 (0/-6) 0.250 (0/-0.25)	(0/-9) (0/-0.4)	12.7000 (0/-11) 0.5000 (0/-0.45)	19.050 (0/-0.2) 0.750 (0/-0.008)		
9.525 3/8	LMB6A	LMB6	LMB6A UU	LMB6 UU	4	9.525 (0/-6) 0.375 (0/-0.25)	(0/-9) (0/-0.4)	15.8750 (0/-13) 0.6250 (0/-0.50)	22.225 (0/-0.2) 0.875 (0/-0.008)		
12.700 1/2	LMB8A	LMB8	LMB8A UU	LMB8 UU	4	12.700 (0/-6) 0.500 (0/-0.25)	(0/-9) (0/-0.4)	22.2250 (0/-13) 0.8750 (0/-0.50)	31.750 (0/-0.2) 1.250 (0/-0.008)		
15.875 5/8	LMB10A	LMB10	LMB10A UU	LMB10 UU	4	15.875 (0/-6) 0.625 (0/-0.25)	(0/-9) (0/-0.4)	28.5750 (0/-13) 1.1250 (0/-0.50)	38.100 (0/-0.2) 1.500 (0/-0.008)		
19.050 3/4	LMB12A	LMB12	LMB12A UU	LMB12 UU	5	19.050 (0/-7) 0.750 (0/-0.3)	(0/-10) (0/-0.4)	31.7500 (0/-16) 1.2500 (0/-0.65)	41.275 (0/-0.2) 1.625 (0/-0.008)		
25.400 1	LMB16A	LMB16	LMB16A UU	LMB16 UU	6	25.400 (0/-7) 1.000 (0/-0.3)	(0/-10) (0/-0.4)	39.6880 (0/-16) 1.5625 (0/-0.65)	57.150 (0/-0.3) 2.250 (0/-0.012)		
31.750 1-1/4	LMB20A	LMB20	LMB20A UU	LMB20 UU	6	31.750 (0/-8) 1.250 (0/-0.35)	(0/-12) (0/-0.5)	50.8000 (0/-19) 2.0000 (0/-0.75)	66.675 (0/-0.3) 2.625 (0/-0.012)		
38.100 1-1/2	LMB24A	LMB24	LMB24A UU	LMB24 UU	6	38.100 (0/-8) 1.500 (0/-0.35)	(0/-12) (0/-0.5)	60.3250 (0/-19) 2.3750 (0/-0.75)	76.200 (0/-0.3) 3.000 (0/-0.012)		
50.800 2	LMB32A	LMB32	LMB32A UU	LMB32 UU	6	50.800 (0/-8) 2.000 (0/-0.35)	(0/-12) (0/-0.5)	76.2000 (0/-22) 3.0000 (0/-0.90)	101.600 (0/-0.3) 4.000 (0/-0.012)		

LINEAR BALL BEARINGS
SERIES LMB

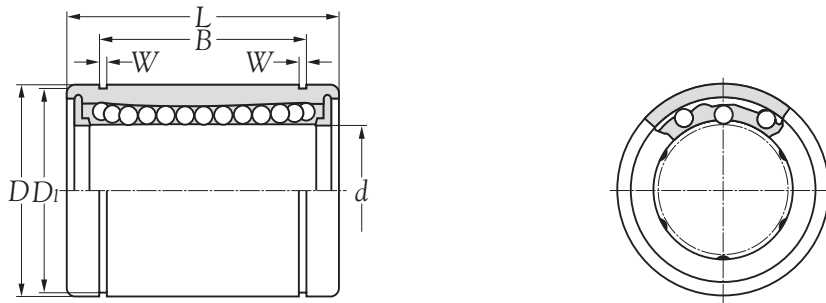

Principal dimensions			Roundness	Steel retainer maximum radial clearance	Resin retainer maximum radial clearance	Load ratings		Mass			
B	W	D ₁				dynamic C	static C ₀	steel retainer	resin retainer		
tolerance			0.001mm/inch	0.001mm/inch	0.001mm/inch	N		kg			
mm/inch											
12.9800 0.5110	(0/-0.2) (0/-0.008)	0.9920 0.0390	11.9060 0.4687	8 0.3	12 0.5	-	-3 -0.1	206	265	-	0.008
16.1500 0.6358	(0/-0.2) (0/-0.008)	0.9920 0.0390	14.9350 0.5880	8 0.3	12 0.5	-3 -0.1	-3 -0.1	225	314	0.015	0.014
24.4600 0.9625	(0/-0.2) (0/-0.008)	1.1680 0.0459	20.8530 0.8209	10 0.4	15 0.6	-4 -0.1	-4 -0.1	510	784	0.042	0.037
28.0400 1.1039	(0/-0.2) (0/-0.008)	1.4220 0.0559	26.8990 1.0590	10 0.4	15 0.6	-4 -0.1	-4 -0.1	774	1180	0.085	0.076
29.6100 1.1657	(0/-0.2) (0/-0.008)	1.4220 0.0599	29.8700 1.1760	8 0.3	12 0.5	-6 -0.2	-6 -0.2	862	1370	0.104	0.095
44.5700 1.7547	(0/-0.3) (0/-0.012)	1.7270 0.0679	37.3060 1.4687	8 0.3	12 0.5	-6 -0.2	-6 -0.2	980	1570	0.220	0.200
2.0047 50.9200	(0/-0.3) (0/-0.012)	1.7270 0.0679	47.9040 1.8859	12 0.5	20 0.8	-8 -0.3	-8 -0.3	1570	2740	0.465	0.440
61.2600 2.4118	(0/-0.3) (0/-0.012)	2.1840 0.0859	56.8700 2.2389	12 0.5	20 0.8	-8 -0.3	-8 -0.3	2180	4020	0.720	0.670
81.0700 3.1917	(0/-0.3) (0/-0.012)	2.6160 0.1029	72.0850 2.8379	17 0.7	25 1.0	-13 -0.5	-13 -0.5	3820	7940	1.310	1.140

LINEAR BALL BEARINGS
SERIES LMB..AJ

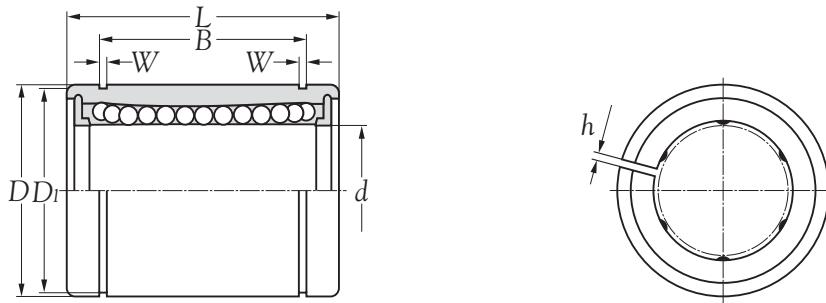

Boundary dimensions <i>d</i> mm/inch	Bearing number				Number of ball tracks	Principal dimensions					
	standard	standard	standard	standard		<i>d</i>		<i>D</i>		<i>L</i>	
	steel retainer	resin retainer	steel retainer	resin retainer		tolerance	tolerance	tolerance	tolerance	tolerance	tolerance
6.350 1/4	-	LMB4-AJ	-	LMB4 UU-AJ	4	6.350 (0/-6) 0.250 (0/-0.25)	(0/-9) (0/-0.4)	12.7000 (0/-11) 0.5000 (0/-0.45)	19.050 (0/-0.2) 0.750 (0/-0.008)		
9.525 3/8	-	LMB6-AJ	-	LMB6 UU-AJ	4	9.525 (0/-6) 0.375 (0/-0.25)	(0/-9) (0/-0.4)	15.8750 (0/-13) 0.6250 (0/-0.50)	22.225 (0/-0.2) 0.875 (0/-0.008)		
12.700 1/2	LMB8A-AJ	LMB8-AJ	LMB8A UU-AJ	LMB8 UU-AJ	4	12.700 (0/-6) 0.500 (0/-0.25)	(0/-9) (0/-0.4)	22.2250 (0/-13) 0.8750 (0/-0.50)	31.750 (0/-0.2) 1.250 (0/-0.008)		
15.875 5/8	LMB10A-AJ	LMB10-AJ	LMB10A UU-AJ	LMB10 UU-AJ	4	15.875 (0/-6) 0.625 (0/-0.25)	(0/-9) (0/-0.4)	28.5750 (0/-13) 1.1250 (0/-0.50)	38.100 (0/-0.2) 1.500 (0/-0.008)		
19.050 3/4	LMB12A-AJ	LMB12-AJ	LMB12A UU-AJ	LMB12 UU-AJ	5	19.050 (0/-7) 0.750 (0/-0.30)	(0/-10) (0/-0.4)	31.7500 (0/-16) 1.2500 (0/-0.65)	41.275 (0/-0.2) 1.625 (0/-0.008)		
25.400 1	LMB16A-AJ	LMB16-AJ	LMB16A UU-AJ	LMB16 UU-AJ	6	25.400 (0/-7) 1.000 (0/-0.30)	(0/-10) (0/-0.4)	39.6880 (0/-16) 1.5625 (0/-0.65)	57.150 (0/-0.3) 2.250 (0/-0.012)		
31.750 1-1/4	LMB20A-AJ	LMB20-AJ	LMB20A UU-AJ	LMB20 UU-AJ	6	31.750 (0/-8) 1.250 (0/-0.35)	(0/-12) (0/-0.5)	50.8000 (0/-19) 2.0000 (0/-0.75)	66.675 (0/-0.3) 2.625 (0/-0.012)		
38.100 1-1/2	LMB24A-AJ	LMB24-AJ	LMB24A UU-AJ	LMB24 UU-AJ	6	38.100 (0/-8) 1.500 (0/-0.35)	(0/-12) (0/-0.5)	60.3250 (0/-19) 2.3750 (0/-0.75)	76.200 (0/-0.3) 3.000 (0/-0.012)		
50.800 2	LMB32A-AJ	LMB32-AJ	LMB32A UU-AJ	LMB32 UU-AJ	6	50.800 (0/-8) 2.000 (0/-0.35)	(0/-12) (0/-0.5)	76.2000 (0/-22) 3.0000 (0/-0.90)	101.600 (0/-0.3) 4.000 (0/-0.012)		

LINEAR BALL BEARINGS
SERIES LMB..AJ

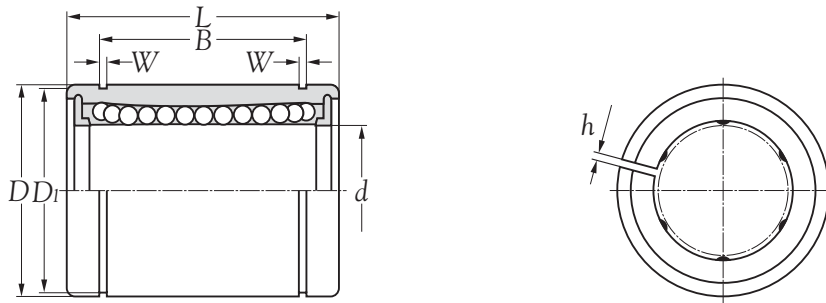

Principal dimensions					Roundness		Steel retainer	Resin retainer	Load ratings		Mass	
B	W	D_1	h			maximum radial clearance	maximum radial clearance	dynamic C	static C_0	steel retainer	resin retainer	
tolerance				0.001mm/inch		0.001mm/inch	0.001mm/inch	N		kg		
mm/inch												
12.9800 0.5110	(0/-0.2) (0/-0.008)	0.9920 0.0390	11.9060 0.4687	1.00 0.04	8 0.3	12 0.5	-	-3 -0.1	206	265	-	0.0080
16.1500 0.6358	(0/-0.2) (0/-0.008)	0.9920 0.0390	14.9350 0.5880	1.00 0.04	8 0.3	12 0.5	-3 -0.1	-3 -0.1	225	314	0.015	0.0140
24.4600 0.9625	(0/-0.2) (0/-0.008)	1.1680 0.0459	20.8530 0.8209	1.50 0.06	8 0.3	12 0.5	-4 -0.1	-4 -0.1	510	784	0.042	0.0370
28.0400 1.1039	(0/-0.2) (0/-0.008)	1.4220 0.0559	26.8990 1.0590	0.06 1.50	8 0.3	12 0.5	-4 -0.1	-4 -0.1	774	1180	0.085	0.0760
29.6100 1.1657	(0/-0.2) (0/-0.008)	1.4220 0.0599	29.8700 1.1760	0.06 1.50	10 0.4	15 0.6	-6 -0.2	-6 -0.2	862	1370	0.104	0.0950
44.5700 1.7547	(0/-0.3) (0/-0.012)	1.7270 0.0679	37.3060 1.4687	1.50 0.06	10 0.4	15 0.6	-6 -0.2	-6 -0.2	980	1570	0.220	0.2000
50.9200 2.0047	(0/-0.3) (0/-0.012)	1.7270 0.0679	47.9040 1.8859	2.50 0.10	12 0.5	20/-8 0.8	-8 -0.3	-8 -0.3	1570	2740	0.465	0.4400
61.2600 2.4118	(0/-0.3) (0/-0.012)	2.1840 0.0859	56.8700 2.2389	3.00 0.12	12 0.5	20/-8 0.8	-8 -0.3	-8 -0.3	4020	720	0.670	0.0381
81.0700 3.1917	(0/-0.3) (0/-0.012)	2.6160 0.1029	72.0850 2.8379	3.00 0.12	17 0.7	25 1.0	-13 -0.5	-13 -0.5	3820	7940	1.310	1.1400

LINEAR BALL BEARINGS
SERIES LMB..OP

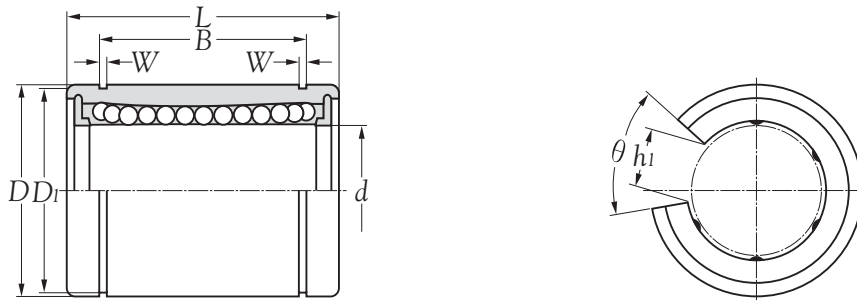

Boundary dimensions <i>d</i> mm/inch	Bearing number				Number of ball tracks	Principal dimensions						
	standard steel retainer	standard resin retainer	standard steel retainer	standard resin retainer		<i>d</i> tolerance		<i>D</i> tolerance		<i>L</i> tolerance		
					mm/inch	0.001mm/inch	mm/inch	0.001mm/inch	mm/inch	0.001mm/inch		
12.700 1/2	LMB8A-OP	LMB 8-OP	LMB 8A UU-OP	LMB8 UU-OP	4	12.700 0.500	(0/-6) (0/-0.25)	(0/-9) (0/-0.4)	22.2250 0.8750	(0/-13) (0/-0.50)	31.750 1.250	(0/-0.2) (0/-0.008)
15.875 5/8	LMB10A-OP	LMB10-OP	LMB10A UU-OP	LMB10 UU-OP	4	15.875 0.625	(0/-6) (0/-0.25)	(0/-9) (0/-0.4)	28.5750 1.1250	(0/-13) (0/-0.50)	38.100 1.500	(0/-0.2) (0/-0.008)
19.050 3/4	LMB12A-OP	LMB12-OP	LMB12A UU-OP	LMB12 UU-OP	5	19.050 0.750	(0/-7) (0/-0.30)	(0/-10) (0/-0.4)	31.7500 1.2500	(0/-16) (0/-0.65)	41.275 1.625	(0/-0.2) (0/-0.008)
25.400 1	LMB16A-OP	LMB16-OP	LMB16A UU-OP	LMB16 UU-OP	6	25.400 1.000	(0/-7) (0/-0.30)	(0/-10) (0/-0.4)	39.6880 1.5625	(0/-16) (0/-0.65)	57.150 2.250	(0/-0.3) (0/-0.012)
31.750 1-1/4	LMB20A-OP	LMB20-OP	LMB20A UU-OP	LMB20 UU-OP	6	31.750 1.250	(0/-8) (0/-0.35)	(0/-12) (0/-0.5)	50.8000 2.0000	(0/-19) (0/-0.75)	66.675 2.625	(0/-0.3) (0/-0.012)
38.100 1-1/2	LMB24A-OP	LMB24-OP	LMB24A UU-OP	LMB24 UU-OP	6	38.100 1.500	(0/-8) (0/-0.35)	(0/-12) (0/-0.5)	60.3250 2.3750	(0/-19) (0/-0.75)	76.200 3.000	(0/-0.3) (0/-0.012)
50.800 2	LMB32A-OP	LMB32-OP	LMB32A UU-OP	LMB32 UU-OP	6	50.800 2.000	(0/-8) (0/-0.35)	(0/-12) (0/-0.5)	76.2000 3.0000	(0/-22) (0/-0.90)	101.600 4.000	(0/-0.3) (0/-0.012)

LINEAR BALL BEARINGS
SERIES LMB..OP

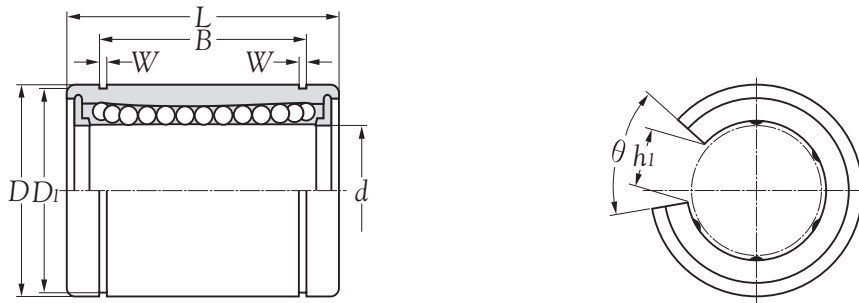

Principal dimensions					Roundness		Steel retainer	Resin retainer	Load ratings		Mass	
B	W	DD1	h1	θ			maximum radial clearance	maximum radial clearance	dynamic C	static Co	steel retainer	resin retainer
tolerance					0.001mm/inch		0.001mm/inch	0.001mm/inch	N		kg	
mm/inch												
24.4600 (0/-0.2)	1.1680	20.8530	7.9375	80°	8	12	-4	-4	510	784	0.042	0.037
0.9625 (0/-0.008)	0.0459	0.8209	0.3400	80°	0.3	0.5	-0.1	-0.1				
28.0400 (0/-0.2)	1.4220	26.8990	9.5250	80°	8	12	-4	-4	774	1180	0.085	0.076
1.1039 (0/-0.008)	0.0559	1.0590	0.3750	80°	0.3	0.5	-0.1	-0.1				
29.6100 (0/-0.2)	1.4220	29.8700	11.1125	60°	10	15	-6	-6	862	1370	0.104	0.095
1.1657 (0/-0.008)	0.0599	1.1760	0.4375	60°	0.4	0.6	-0.2	-0.2				
44.5700 (0/-0.3)	1.7270	37.3060	14.2875	50°	10	15	-6	-6	980	1570	0.220	0.200
1.7547 (0/-0.012)	0.0679	1.4687	0.5625	50°	0.4	0.6	-0.2	-0.2				
50.9200 (0/-0.3)	1.7270	47.9040	15.8750	50°	12	20	-8	-8	1570	2740	0.465	0.440
2.0047 (0/-0.012)	0.0679	1.8859	0.6250	50°	0.5	0.8	-0.3	-0.3				
61.2600 (0/-0.3)	2.1840	56.8700	19.0500	50°	12	20	-8	-8	2180	4020	0.720	0.670
2.4118 (0/-0.012)	0.0859	2.2389	0.7500	50°	0.5	0.8	-0.3	-0.3				
3.1917 (0/-0.3)	2.6160	72.0850	2.5400	50°	17	25	-13	-13	3820	7940	1.310	1.140
81.0700 (0/-0.012)	0.1029	2.8379	1.0000	50°	0.7	1.0	-0.5	-0.5				

LINEAR BALL BEARINGS
SERIES LMB..F

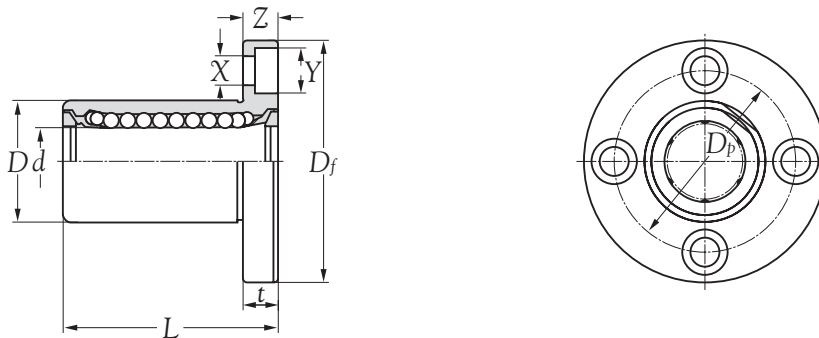

Boundary dimensions <i>d</i> mm/inch	Bearing number		Number of ball tracks	Principal dimensions					
	standard resin retainer	with seals resin retainer		<i>d</i> tolerance	<i>D</i> tolerance	<i>L</i> tolerance	<i>d</i> mm/inch	<i>D</i> mm/inch	<i>L</i> mm/inch
6.350 1/4	LMBF4	LMBF4 UU	4	6.350 (0/-9) 0.250 (0/-0.4)	12.7000 (0/-13) 0.5000 (0/-0.50)	19.050 (±0.3) 0.750 (±0.012)			
9.525 3/8	LMBF6	LMBF6 UU	4	9.525 (0/-9) 0.375 (0/-0.4)	15.8750 (0/-16) 0.6250 (0/-0.65)	22.225 (±0.3) 0.875 (±0.012)			
12.700 1/2	LMBF8	LMBF8 UU	4	12.700 (0/-9) 0.500 (0/-0.4)	22.2250 (0/-16) 0.8750 (0/-0.65)	31.750 (±0.3) 1.250 (±0.012)			
15.875 5/8	LMBF10	LMBF10 UU	4	15.875 (0/-9) 0.625 (0/-0.4)	28.5750 (0/-16) 1.1250 (0/-0.65)	38.100 (±0.3) 1.500 (±0.012)			
19.050 3/4	LMBF12	LMBF12 UU	4	19.050 (0/-1) 0.750 (0/-0.4)	31.7500 (0/-19) 1.2500 (0/-0.75)	41.275 (±0.3) 1.625 (±0.012)			
25.400 1	LMBF16	LMBF16 UU	5	25.400 (0/-1) 1.000 (0/-0.4)	39.6880 (0/-19) 1.5625 (0/-0.75)	57.150 (±0.3) 2.250 (±0.012)			
31.750 1-1/4	LMBF20	LMBF20 UU	5	31.750 (0/-12) 1.250 (0/-0.5)	50.8000 (0/-22) 2.0000 (0/-0.90)	66.675 (±0.3) 2.625 (±0.012)			
38.100 1-1/2	LMBF24	LMBF24 UU	6	38.100 (0/-12) 1.500 (0/-0.5)	60.3250 (0/-22) 2.3750 (0/-0.90)	76.200 (±0.3) 3.000 (±0.012)			
50.800 2	LMBF32	LMBF32 UU	6	50.800 (0/-12) 2.000 (0/-0.5)	76.2000 (0/-25) 3.0000 (0/-1.00)	101.600 (±0.3) 4.000 (±0.012)			
63.500 2-1/2	LMBF40	LMBF40 UU	6	63.500 (0/-15) 2.500 (0/-0.6)	95.2500 (0/-25) 3.7500 (0/-1.00)	127.000 (±0.3) 5.000 (±0.012)			
76.200 3	LMBF48	LMBF48 UU	6	76.200 (0/-15) 3.000 (0/-0.6)	114.3000 (0/-25) 4.5000 (0/-1.00)	152.400 (±0.3) 6.000 (±0.012)			
101.600 4	LMBF64	LMBF64 UU	6	101.600 (0/-20) 4.000 (0/-0.8)	152.4000 (0/-29) 6.0000 (0/-1.15)	203.200 (±0.3) 8.000 (±0.012)			

LINEAR BALL BEARINGS

SERIES LMB..F

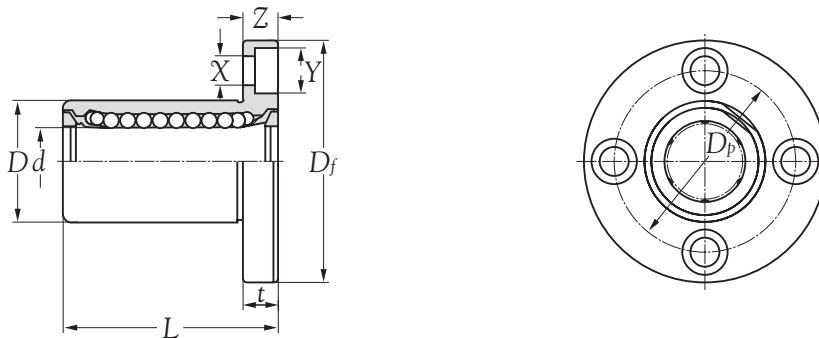

D_f	Principal dimensions flange			Roundness	Squareness	Load ratings		Mass kg (approx.)
	t	D_p	XxYxZ			dynamic C	static C_o	
	mm/inch			0.001mm/Inch	0.001mm/Inch	N		
31.7500 1.2500	5.5560 0.2190	22.2250 0.8750	3.9690 x 6.3500 x 3.5720 0.1560 x 0.2500 x 0.1410	12 0.5	12 0.5	206	265	0.032
38.1000 1.5000	6.3500 0.2500	26.9880 1.0620	4.7630 x 7.5410 x 4.3660 0.1875 x 0.2970 x 0.1720	12 0.5	12 0.5	225	314	0.047
44.4500 1.7500	6.3500 0.2500	33.3380 1.3120	4.7630 x 7.5410 x 4.3660 0.1875 x 0.2970 x 0.1720	12 0.5	12 0.5	510	784	0.088
50.8000 2.0000	6.3500 0.2500	39.6888 1.5620	4.7630 x 7.5410 x 4.3660 0.1875 x 0.2970 x 0.1720	15 0.6	15 0.6	774	1180	0.140
55.5630 2.1875	7.9380 0.3125	43.6600 1.7180	5.5560 x 8.7310 x 5.1590 0.2187 x 0.3440 x 0.2030	15 0.6	15 0.6	862	1370	0.190
63.5000 2.5000	7.9380 0.3125	51.5940 2.0310	5.5560 x 8.7310 x 5.1590 0.2187 x 0.3440 x 0.2030	15 0.6	15 0.6	980	1570	0.325
79.3750 3.1250	9.5250 0.3750	65.0880 2.5625	7.1440 x 10.319 x 6.7470 0.2812 x 0.4060 x 0.2656	20 0.8	20 0.8	1570	2740	0.665
95.2500 3.7500	12.7000 0.5000	77.7880 3.0625	8.7310 x 12.700 x 8.3340 0.3440 x 0.5000 x 0.3280	25 1.0	25 1.0	2180	4020	1.100
111.1250 4.3750	12.7000 0.5000	93.6620 3.6875	8.7310 x 12.700 x 8.3340 0.3440 x 0.5000 x 0.3280	25 1.0	25 1.0	3820	7940	1.760
136.5250 5.3750	19.0500 0.7500	115.8870 4.5625	10.319 x 15.875 x 9.5500 0.4062 x 0.6250 x 0.3750	25 1.0	25 1.0	4700	10000	3.570
155.5750 6.1250	19.0500 0.7500	134.9370 5.3125	10.319 x 15.875 x 9.5250 0.4062 x 0.6250 x 0.3750	25 1.0	25 1.0	7350	16000	5.600
203.2000 8.0000	22.2250 0.8750	177.8000 7.0000	12.700 x 18.097 x 12.700 0.5000 x 0.7125 x 0.5000	30 1.2	30 1.2	14100	34800	12.000

LINEAR BALL BEARINGS
SERIES LMB..K

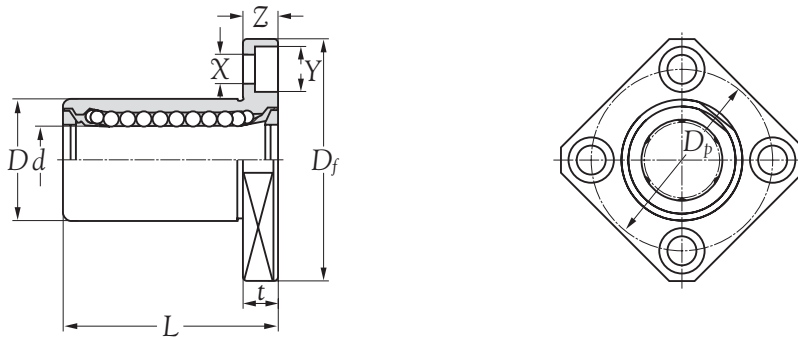

Boundary dimensions <i>d</i> mm/inch	Bearing number		Number of ball tracks	Principal dimensions					
	standard resin retainer	with seals resin retainer		<i>d</i> tolerance		<i>D</i> tolerance		<i>L</i> tolerance	
				mm/inch	0.001mm/Inch	mm/inch	0.001mm/Inch	mm/inch	
6.350 1/4	LMBK4	LMBK4 UU	4	6.350 0.250	(0/-9) (0/-0.4)	12.7000 0.5000	(0/-13) (0/-0.50)	19.050 0.750	(±0.3) (±0.012)
9.525 3/8	LMBK6	LMBK6 UU	4	9.525 0.375	(0/-9) (0/-0.4)	15.8750 0.6250	(0/-16) (0/-0.65)	22.225 0.875	(±0.3) (±0.012)
12.700 1/2	LMBK8	LMBK8 UU	4	12.700 0.500	(0/-9) (0/-0.4)	22.2250 0.8750	(0/-16) (0/-0.65)	31.750 1.250	(±0.3) (±0.012)
15.875 5/8	LMBK10	LMBK10 UU	4	15.875 0.625	(0/-9) (0/-0.4)	28.5750 1.1250	(0/-16) (0/-0.65)	38.100 1.500	(±0.3) (±0.012)
19.050 3/4	LMBK12	LMBK12 UU	4	19.050 0.750	(0/-1) (0/-0.4)	31.7500 1.2500	(0/-19) (0/-0.75)	41.275 1.625	(±0.3) (±0.012)
25.400 1	LMBK16	LMBK16 UU	5	25.400 1.000	(0/-1) (0/-0.4)	39.6880 1.5625	(0/-19) (0/-0.75)	57.150 2.250	(±0.3) (±0.012)
31.750 1-1/4	LMBK20	LMBK20 UU	5	31.750 1.250	(0/-12) (0/-0.5)	50.8000 2.0000	(0/-22) (0/-0.90)	66.675 2.625	(±0.3) (±0.012)
38.100 1-1/2	LMBK24	LMBK24 UU	6	38.100 1.500	(0/-12) (0/-0.5)	60.3250 2.3750	(0/-22) (0/-0.90)	76.200 3.000	(±0.3) (±0.012)
50.800 2	LMBK32	LMBK32 UU	6	50.800 2.000	(0/-12) (0/-0.5)	76.2000 3.0000	(0/-0.25) (0/-1.00)	101.600 4.000	(±0.3) (±0.012)
63.500 2-1/2	LMBK40	LMBK40 UU	6	63.500 2.500	(0/-15) (0/-0.6)	95.2500 3.7500	(0/-0.25) (0/-1.00)	127.000 5.000	(±0.3) (±0.012)
76.200 3	LMBK48	LMBK48 UU	6	76.200 3.000	(0/-15) (0/-0.6)	114.3000 4.5000	(0/-0.25) (0/-1.00)	152.400 6.000	(±0.3) (±0.012)
101.600 4	LMBK64	LMBK64 UU	6	101.600 4.000	(0/-20) (0/-0.8)	152.4000 6.0000	(0/-29) (0/-1.15)	203.200 8.000	(±0.3) (±0.012)

LINEAR BALL BEARINGS

SERIES LMB..K

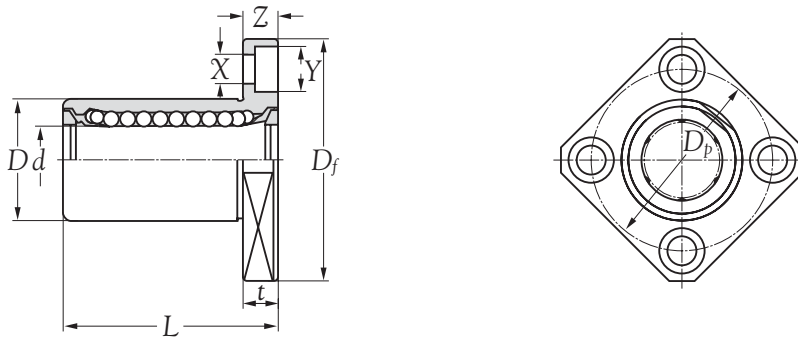

D_f	Principal dimensions flange			Roundness	Squareness	Load ratings		Mass kg (approx.)
	t	D_p	XxYxZ			dynamic C	static C_o	
	mm/inch			0.001mm/inch	0.001mm/inch	N		
31.7500 1.2500	5.5560 0.2190	22.2250 0.8750	3.9690 x 6.3500 x 3.5720 0.1560 x 0.2500 x 0.1410	12 0.5	12 0.5	206	265	0.032
38.1000 1.5000	6.3500 0.2500	26.9880 1.0620	4.7630 x 7.5410 x 4.3660 0.1875 x 0.2970 x 0.1720	12 0.5	12 0.5	225	314	0.047
44.4500 1.7500	6.3500 0.2500	33.3380 1.3120	4.7630 x 7.5410 x 4.3660 0.1875 x 0.2970 x 0.1720	12 0.5	12 0.5	510	784	0.088
50.8000 2.0000	6.3500 0.2500	39.6888 1.5620	4.7630 x 7.5410 x 4.3660 0.1875 x 0.2970 x 0.1720	15 0.6	15 0.6	774	1180	0.140
55.5630 2.1875	7.9380 0.3125	43.6600 1.7180	5.5560 x 8.7310 x 5.1590 0.2187 x 0.3440 x 0.2030	15 0.6	15 0.6	862	1370	0.190
63.5000 2.5000	7.9380 0.3125	51.5940 2.0310	5.5560 x 8.7310 x 5.1590 0.2187 x 0.3440 x 0.2030	15 0.6	15 0.6	980	1570	0.325
79.3750 3.1250	9.5250 0.3750	65.0880 2.5625	7.1440 x 10.319 x 6.7470 0.2812 x 0.4060 x 0.2656	20 0.8	20 0.8	1570	2740	0.665
95.2500 3.7500	12.7000 0.5000	77.7880 3.0625	8.7310 x 12.700 x 8.3340 0.3440 x 0.5000 x 0.3280	25 1.0	25 1.0	2180	4020	1.100
111.1250 4.3750	12.7000 0.5000	93.6620 3.6875	8.7310 x 12.700 x 8.3340 0.3440 x 0.5000 x 0.3280	25 1.0	25 1.0	3820	7940	1.760
136.5250 5.3750	19.0500 0.7500	115.8870 4.5625	10.319 x 15.875 x 9.5500 0.4062 x 0.6250 x 0.3750	25 1.0	25 1.0	4700	10000	3.570
155.5750 6.1250	19.0500 0.7500	134.9370 5.3125	10.319 x 15.875 x 9.5250 0.4062 x 0.6250 x 0.3750	25 1.0	25 1.0	7350	16000	5.600
203.2000 8.0000	22.2250 0.8750	177.8000 7.0000	12.700 x 18.097 x 12.700 0.5000 x 0.7125 x 0.5000	30 1.2	30 1.2	14100	34800	12.000

LINEAR BALL BEARINGS
SERIES LME..

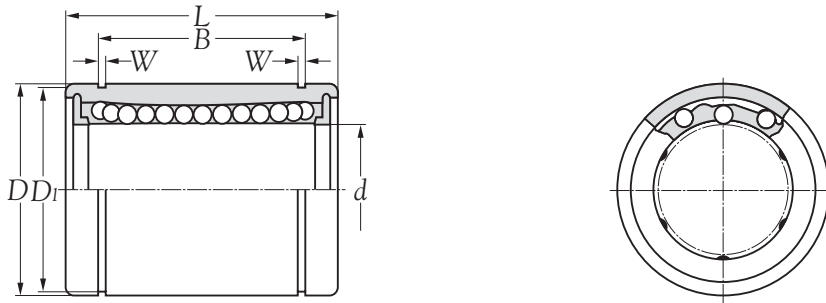

Boundary dimensions <i>d</i> mm	Bearing number				Number of ball tracks	Principal dimensions					
	standard steel retainer	standard resin retainer	with seals steel retainer	with seals resin retainer		<i>d</i>		<i>D</i>		<i>L</i>	
						mm	0.001mm	mm	0.001mm	mm	mm
5	-	LME5	-	LME5 UU	3	5	(+8/0)	12	(0/-8)	22	(0/-0.2)
8	LME8A	LME8	LME8A UU	LME8 UU	4	8	(+8/0)	16	(0/-8)	25	(0/-0.2)
10	LME10A	-	LME10A UU	-	4	10	(+8/0)	19	(0/-9)	29	(0/-0.2)
12	LME12A	LME12	LME12A UU	LME12 UU	4	12	(+8/0)	22	(0/-9)	32	(0/-0.2)
16	LME16A	LME16	LME16A UU	LME16 UU	5	16	(+9/-1)	26	(0/-9)	36	(0/-0.2)
20	LME20A	LME20	LME20A UU	LME20 UU	5	20	(+9/-1)	32	(0/-11)	45	(0/-0.2)
25	LME25A	LME25	LME25A UU	LME25 UU	6	25	(+11/-1)	40	(0/-11)	58	(0/-0.3)
30	LME30A	LME30	LME30A UU	LME30 UU	6	30	(+11/-1)	47	(0/-11)	68	(0/-0.3)
40	LME40A	LME40	LME40A UU	LME40 UU	6	40	(+13/-2)	62	(0/-13)	80	(0/-0.3)
50	LME50A	LME50	LME50A UU	LME50 UU	6	50	(+13/-2)	75	(0/-13)	100	(0/-0.3)
60	LME60A	LME60	LME60A UU	LME60 UU	6	60	(+13/-2)	90	(0/-15)	125	(0/-0.4)

LINEAR BALL BEARINGS

SERIES LME..

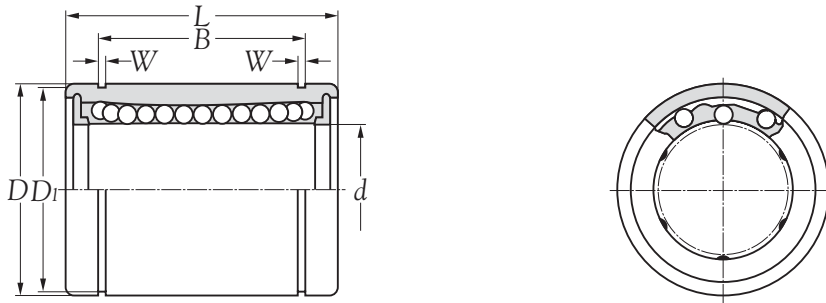

Principal dimensions			Roundness	Steel retainer maximum radial clearance	Resin retainer maximum radial clearance	Load ratings		Mass	
B tolerance	W mm	D ₁				dynamc C	static C ₀	steel retainer	resin retainer
			0.001mm	0.001mm	0.001mm	N		kg	
14.5 (0/-0.2)	1.10	11.5	12	-	-5	206	265	-	0.011
16.5 (0/-0.2)	1.10	15.2	12	-3	-5	265	402	0.022	0.020
22.0 (0/-0.2)	1.30	18.0	12	-4	-	372	549	0.036	-
22.9 (0/-0.2)	1.30	21.0	12	-4	-7	510	784	0.045	0.041
24.9 (0/-0.2)	1.30	24.9	12	-4	-7	578	892	0.060	0.065
31.5 (0/-0.2)	1.60	30.3	15	-6	-9	862	1370	0.102	0.091
44.1 (0/-0.3)	1.85	37.5	15	-6	-9	980	1570	0.235	0.215
52.1 (0/-0.3)	1.85	44.5	15	-8	-9	1570	2740	0.360	0.325
60.6 (0/-0.3)	2.15	59.0	17	-8	-13	2160	4020	0.770	0.705
77.6 (0/-0.3)	2.65	72.0	17	-13	-13	3820	7940	1.250	1.130
101.7 (0/-0.4)	3.15	86.5	20	-13	-16	4700	9800	2.220	2.220

LINEAR BALL BEARINGS
SERIES LME..AJ

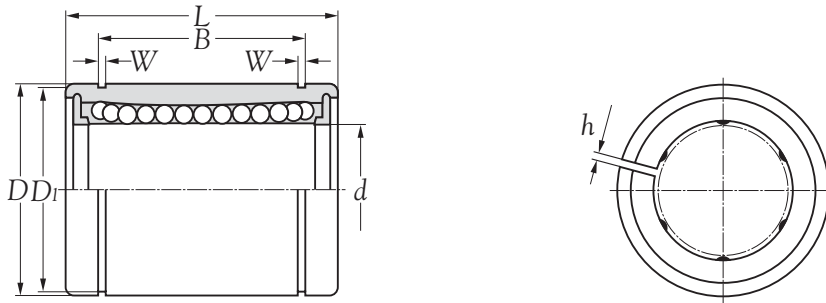

Boundary dimensions <i>d</i> mm	Bearing number				Number of ball tracks	Principal dimensions					
	standard steel retainer	standard resin retainer	with seals steel retainer	with seals resin retainer		<i>d</i>		<i>D</i>		<i>L</i>	
						tolerance mm	0.001mm	tolerance mm	0.001mm	tolerance mm	mm
5	-	LME5-AJ	-	LME5 UU-AJ	3	5	(+8/0)	12	(0/-8)	22	(0/-0.2)
8	-	LME8-AJ	-	LME8 UU-AJ	4	8	(+8/0)	16	(0/-8)	25	(0/-0.2)
12	LME12A-AJ	LME12-AJ	LME12A UU-AJ	LME12 UU-AJ	4	12	(+8/0)	22	(0/-9)	32	(0/-0.2)
16	LME16A-AJ	LME16-AJ	LME16A UU-AJ	LME16 UU-AJ	5	16	(+9/-1)	26	(0/-9)	36	(0/-0.2)
20	LME20A-AJ	LME20-AJ	LME20A UU-AJ	LME20 UU-AJ	5	20	(+9/-1)	32	(0/-11)	45	(0/-0.2)
25	LME25A-AJ	LME25-AJ	LME25A UU-AJ	LME25 UU-AJ	6	25	(+11/-1)	40	(0/-11)	58	(0/-0.3)
30	LME30A-AJ	LME30-AJ	LME30A UU-AJ	LME30 UU-AJ	6	30	(+11/-1)	47	(0/-11)	68	(0/-0.3)
40	LME40A-AJ	LME40-AJ	LME40A UU-AJ	LME40 UU-AJ	6	40	(+13/-2)	62	(0/-13)	80	(0/-0.3)
50	LME50A-AJ	LME50-AJ	LME50A UU-AJ	LME50 UU-AJ	6	50	(+13/-2)	75	(0/-13)	100	(0/-0.3)
60	LME60A-AJ	LME60-AJ	LME60A UU-AJ	LME60 UU-AJ	6	60	(+13/-2)	90	(0/-15)	125	(0/-0.4)

LINEAR BALL BEARINGS
SERIES LME..AJ

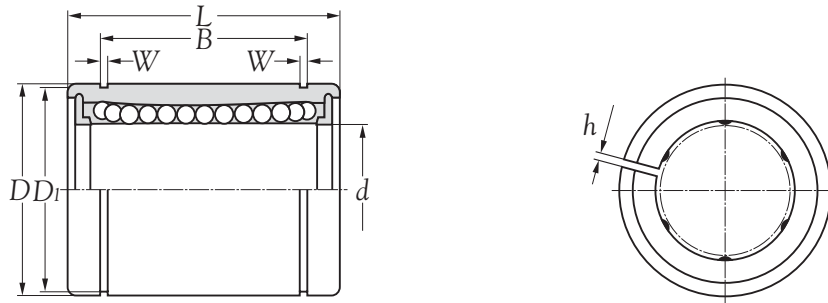

B	Principal dimensions				Roundness	Steel retainer maximum radial clearance	Resin retainer maximum radial clearance	Load ratings		Mass	
	tolerance	W	D_i	h				dynamic C	static C_o	steel retainer	resin retainer
	mm	mm	mm	mm	0.001mm	0.001mm	0.001mm	N		kg	
14.5	(0/-0.2)	1.10	11.5	1.0	12	-	-5	206	265	0.011	-
16.5	(0/-0.2)	1.10	15.2	1.0	12	-3	-5	265	402	0.020	0.022
22.9	(0/-0.2)	1.30	21.0	1.5	12	-4	-7	510	784	0.041	0.045
24.9	(0/-0.2)	1.30	24.9	1.5	12	-4	-7	578	892	0.065	0.060
31.5	(0/-0.2)	1.60	30.3	2.0	15	-6	-9	862	1370	0.091	0.102
44.1	(0/-0.3)	1.85	37.5	2.0	15	-6	-9	980	1570	0.215	0.235
52.1	(0/-0.3)	1.85	44.5	2.0	15	-8	-9	1570	2740	0.325	0.360
60.6	(0/-0.3)	2.15	59.0	3.0	17	-8	-13	2160	4020	0.705	0.770
77.6	(0/-0.3)	2.65	72.0	3.0	17	-13	-13	3820	7940	1.130	1.250
101.7	(0/-0.4)	3.15	86.5	3.0	20	-13	-16	4700	9800	2.220	2.220

LINEAR BALL BEARINGS
SERIES LME..OP

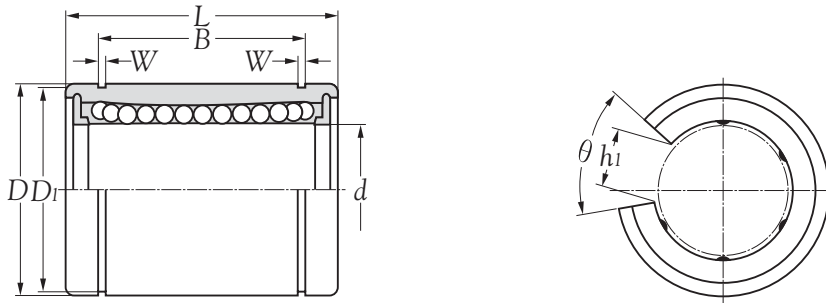

Boundary dimensions <i>d</i> mm	Bearing number				Number of ball tracks	Principal dimensions					
	standard	standard	with seals	with seals		<i>d</i>		<i>D</i>		<i>L</i>	
	steel retainer	resin retainer	steel retainer	resin retainer		tolerance	0.001mm	tolerance	0.001mm	tolerance	mm
12	LME12A-OP	LME12-OP	LME12A UU-OP	LME12 UU-OP	4	12	(+8/0)	22	(0/-9)	32	(0/-0.2)
16	LME16A-OP	LME16-OP	LME16A UU-OP	LME16 UU-OP	5	16	(+9/-1)	26	(0/-9)	36	(0/-0.2)
20	LME20A-OP	LME20-OP	LME20A UU-OP	LME20 UU-OP	5	20	(+9/-1)	32	(0/-11)	45	(0/-0.2)
25	LME25A-OP	LME25-OP	LME25A UU-OP	LME25 UU-OP	6	25	(+11/-1)	40	(0/-11)	58	(0/-0.3)
30	LME30A-OP	LME30-OP	LME30A UU-OP	LME30 UU-OP	6	30	(+11/-1)	47	(0/-11)	68	(0/-0.3)
40	LME40A-OP	LME40-OP	LME40A UU-OP	LME40 UU-OP	6	40	(+13/-2)	62	(0/-13)	80	(0/-0.3)
50	LME50A-OP	LME50-OP	LME50A UU-OP	LME50 UU-OP	6	50	(+13/-2)	75	(0/-13)	100	(0/-0.4)
60	LME60A-OP	LME60-OP	LME60A UU-OP	LME60 UU-OP	6	60	(+13/-2)	90	(0/-15)	125	(0/-0.4)

LINEAR BALL BEARINGS
SERIES LME..OP

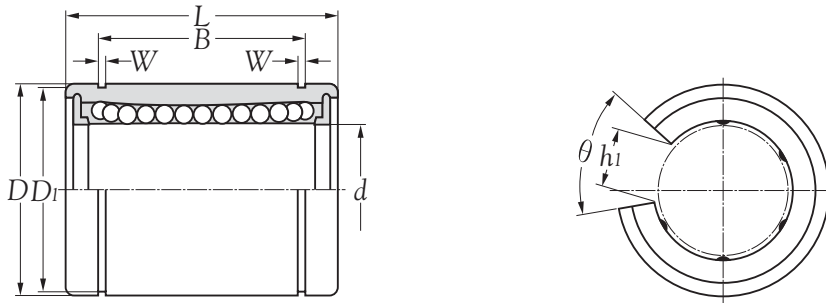

B	Principal dimensions				Roundness	Steel retainer maximum radial clearance	Resin retainer maximum radial clearance	Load ratings		Mass		
	tolerance	W	D ₁	h ₁				θ	dynamic C	static C ₀	steel retainer	resin retainer
	mm	mm	mm	°	0.001mm	0.001mm	0.001mm	N		kg	kg	
22.9	(0/-0.2)	1.30	21.0	7.5	78°	12	-4	-7	510	784	0.045	0.041
24.9	(0/-0.2)	1.30	24.9	10.0	78°	12	-4	-7	578	892	0.060	0.065
31.5	(0/-0.2)	1.60	30.3	10.0	60°	15	-6	-9	862	1370	0.102	0.091
44.1	(0/-0.3)	1.85	37.5	12.5	60°	15	-6	-9	980	1570	0.235	0.215
52.1	(0/-0.3)	1.85	44.5	12.5	50°	15	-8	-9	1570	2740	0.360	0.325
60.6	(0/-0.3)	2.15	59.0	16.8	50°	17	-8	-13	2160	4020	0.770	0.705
77.6	(0/-0.4)	2.65	72.0	21.0	50°	17	-13	-13	3820	7940	1.250	1.130
101.7	(0/-0.4)	3.15	86.5	27.2	54°	20	-13	-16	4700	9800	2.220	2.220

LINEAR BALL BEARINGS
SERIES LME..F

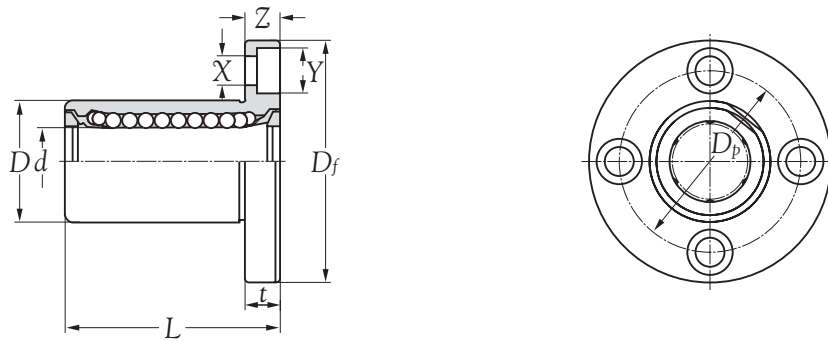

Boundary dimensions <i>d</i> mm	Bearing number		Number of ball tracks	Principal dimensions					
	standard resin retainer	with seals resin retainer		<i>d</i>		<i>D</i>		<i>L</i>	
				tolerance mm	0.001mm	tolerance mm	0.001mm	tolerance mm	mm
8	LMEF8	LMEF8 UU	4	8	(+8/0)	16	(0/-13)	25	(±0.3)
12	LMEF12	LMEF12 UU	4	12	(+8/0)	22	(0/-16)	32	(±0.3)
16	LMEF16	LMEF16 UU	5	16	(+9/-1)	26	(0/-16)	36	(±0.3)
20	LMEF20	LMEF20 UU	5	20	(+9/-1)	32	(0/-19)	45	(±0.3)
25	LMEF25	LMEF25 UU	6	25	(+11/-1)	40	(0/-19)	58	(±0.3)
30	LMEF30	LMEF30 UU	6	30	(+11/-1)	47	(0/-19)	68	(±0.3)
40	LMEF40	LMEF40 UU	6	40	(+13/-2)	62	(0/-22)	80	(±0.3)
50	LMEF50	LMEF50 UU	6	50	(+13/-2)	75	(0/-22)	100	(±0.3)
60	LMEF60	LMEF60 UU	6	60	(+13/-2)	90	(0/-25)	125	(±0.3)

LINEAR BALL BEARINGS
SERIES LME..F

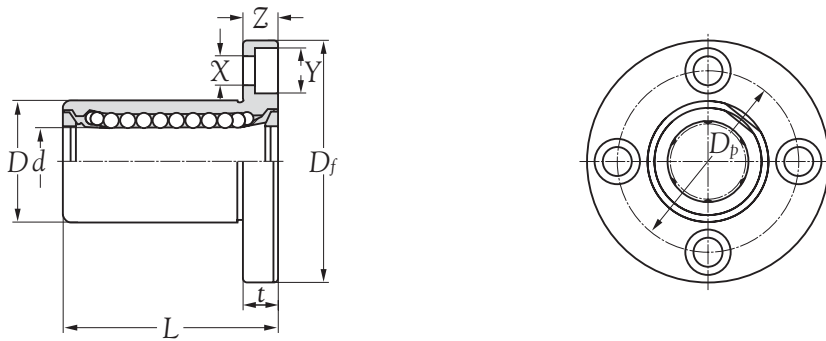

D_f	Principa dimensions flange			Roundness	Squareness	Load ratings		Mass kg (approx.)
	t	D_p	$X \times Y \times Z$			dynamic C	static C_o	
	mm			0.001mm	0.001mm	N		
32	5	24	3.5 x 6.0 x 3.1	12	12	265	402	0.041
42	6	32	4.5 x 7.5 x 4.1	12	12	510	784	0.080
46	6	36	4.5 x 7.5 x 4.1	12	12	578	892	0.103
54	8	43	5.5 x 9.0 x 5.1	15	15	862	1370	0.182
62	8	51	5.5 x 9.0 x 5.1	15	15	980	1570	0.335
76	10	62	6.6 x 11 x 6.1	15	15	1570	2740	0.560
98	13	80	9.0 x 14 x 8.1	17	17	2160	4020	1.175
112	13	94	9.0 x 14 x 8.1	17	17	3820	7940	1.745
134	18	112	11 x 17 x 11.1	20	20	4700	9800	3.220

LINEAR BALL BEARINGS
SERIES LME..K

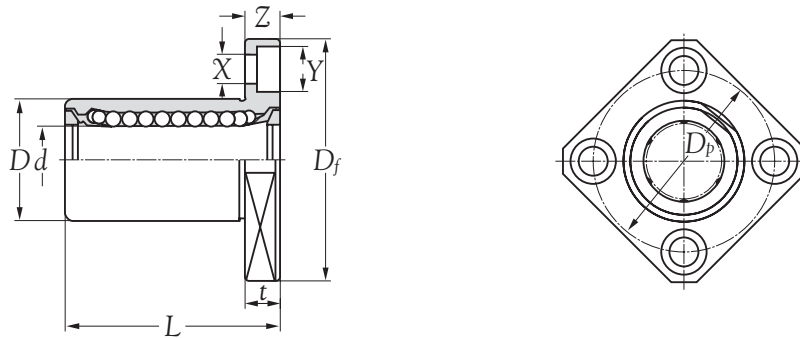

Boundary dimensions mm	Bearing number		Number of ball tracks	Principal dimensions					
	standard resin retainer	with seals resin retainer		d		D		L	
				tolerance mm	0.001mm	tolerance mm	0.001mm	tolerance mm	mm
8	LMEK8	LMEK8 UU	4	8	(+8/0)	16	(0/-13)	25	(±0.3)
12	LMEK12	LMEK12 UU	4	12	(+8/0)	22	(0/-16)	32	(±0.3)
16	LMEK16	LMEK16 UU	5	16	(+9/-1)	26	(0/-16)	36	(±0.3)
20	LMEK20	LMEK20 UU	5	20	(+9/-1)	32	(0/-19)	45	(±0.3)
25	LMEK25	LMEK25 UU	6	25	(+11/-1)	40	(0/-19)	58	(±0.3)
30	LMEK30	LMEK30 UU	6	30	(+11/-1)	47	(0/-19)	68	(±0.3)
40	LMEK40	LMEK40 UU	6	40	(+13/-2)	62	(0/-22)	80	(±0.3)
50	LMEK50	LMEK50 UU	6	50	(+13/-2)	75	(0/-22)	100	(±0.3)
60	LMEK60	LMEK60 UU	6	60	(+13/-2)	90	(0/-25)	125	(±0.3)

LINEAR BALL BEARINGS
SERIES LME..K

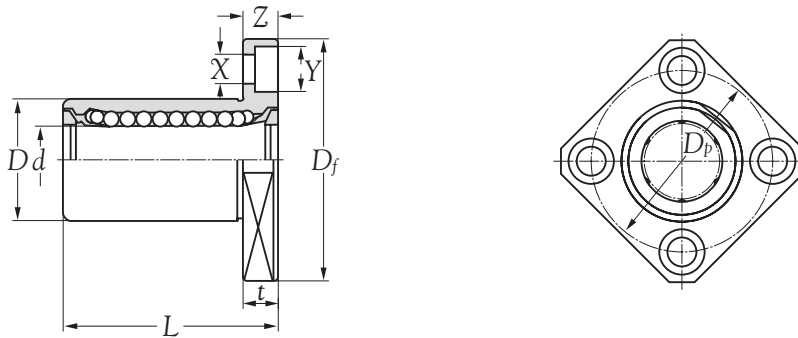

D_f	Principa dimensions flange			Roundness	Squareness	Load ratings		Mass kg (approx.)
	t	D_p	$X \times Y \times Z$			dynamic C	static C_o	
	mm			0.001mm	0.001mm	N		
32	5	24	3.5 x 6.0 x 3.1	12	12	265	402	0.041
42	6	32	4.5 x 7.5 x 4.1	12	12	510	784	0.080
46	6	36	4.5 x 7.5 x 4.1	12	12	578	892	0.103
54	8	43	5.5 x 9.0 x 5.1	15	15	862	1370	0.182
62	8	51	5.5 x 9.0 x 5.1	15	15	980	1570	0.335
76	10	62	6.6 x 11 x 6.1	15	15	1570	2740	0.560
98	13	80	9.0 x 14 x 8.1	17	17	2160	4020	1.175
112	13	94	9.0 x 14 x 8.1	17	17	3820	7940	1.745
134	18	112	11.0 x 17 x 11.1	20	20	4700	9800	3.220

LINEAR BALL BEARINGS
SERIES KH

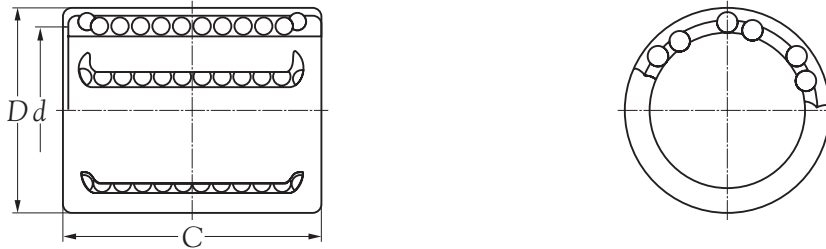

Boundary dimensions <i>d</i> mm	Bearing number	Number of ball tracks	Principal dimensions		Basic load ratings		Max runout speed		Mass kg (approx.)
			<i>D</i> mm	<i>C</i> mm	dynamic <i>N</i>	static	grease <i>C</i> r/min	oil <i>C_o</i>	
6	KH0622	4	12	22	400	239	41	24	0.0070
6	KH0622 PP	4	12	22	400	239	41	24	0.0070
8	KH0824	4	15	24	435	280	44	29	0.0120
8	KH0824 PP	4	15	24	435	280	44	29	0.0120
10	KH1026	4	17	26	500	370	51	38	0.0145
10	KH1026 PP	4	17	26	500	370	51	38	0.0145
12	KH1228	5	19	28	620	510	63	52	0.0185
12	KH1228 PP	5	19	28	620	510	63	52	0.0185
14	KH1428	5	21	28	620	520	63	53	0.0205
14	KH1428 PP	5	21	28	620	520	63	53	0.0205
16	KH1630	5	24	30	800	620	82	63	0.0275
16	KH1630 PP	5	24	30	800	620	82	63	0.0275
20	KH2030	6	28	30	950	790	97	81	0.0325
20	KH2030 PP	6	28	30	950	790	97	81	0.0325
25	KH2540	6	35	40	1990	1670	203	170	0.0660
25	KH2540 PP	6	35	40	1990	1670	203	170	0.0660
30	KH3050	7	40	50	2800	2700	285	275	0.0950
30	KH3050 PP	7	40	50	2800	2700	285	275	0.0950
40	KH4060	8	52	60	4400	4450	449	454	0.1820
40	KH4060 PP	8	52	60	4400	4450	449	454	0.1820
50	KH5070	9	62	70	5500	6300	561	642	0.2520
50	KH5070 PP	9	62	70	5500	6300	561	642	0.2520